

TFT DISPLAY SPECIFICATION



WINSTAR Display Co.,Ltd.
華凌光電股份有限公司



Winstar Display Co., LTD

華凌光電股份有限公司

WEB: <http://www.winstar.com.tw> E-mail: sales@winstar.com.tw



SPECIFICATION

CUSTOMER : _____

MODULE NO.: WF35HTLAIDNNO#

<p>APPROVED BY:</p> <p>(FOR CUSTOMER USE ONLY)</p>	<p>PCB VERSION: _____</p> <p>DATA: _____</p>
---	--

SALES BY	APPROVED BY	CHECKED BY	PREPARED BY
			葉虹蘭
ISSUED DATE: 2017/06/15			



RECORDS OF REVISION

DOC. FIRST ISSUE

VERSION	DATE	REVISED PAGE NO.	SUMMARY
0	2016/05/19		First issue
A	2016/08/10		Modify Vibration test.
B	2016/10/05		Modify Summary Add Aspect Ratio
C	2017/06/02		Modify Brightness.
D	2017/06/15		Modify Electrical Characteristics. Add DC Characteristics & AC Characteristics

Contents

1.Module Classification Information

2.Summary

3.General Specification

4.Absolute Maximum Ratings

5.Electrical Characteristics

6.DC Characteristics

7.AC Characteristics

8.Optical Characteristics

9.Interface

10.Block Diagram

11.Reliability

12.Contour Drawing

13.Other

WINSTAR DISPLAY Co., Ltd.

1.Module Classification Information

W F 35 H T L A I D N N 0 #
 ① ② ③ ④ ⑤ ⑥ ⑦ ⑧ ⑨ ⑩ ⑪ ⑫ ⑬

①	Brand : WINSTAR DISPLAY CORPORATION											
②	Display Type : F→TFT Type, J→Custom TFT											
③	Display Size : 3.5" TFT											
④	Model serials no.											
⑤	Backlight Type :	F→CCFL, White S→LED, High Light White				T→LED, White Z→Nichia LED, White						
⑥	LCD Polarize Type/ Temperature range/ Gray Scale Inversion Direction	A→Transmissive, N.T, IPS TFT C→Transmissive, N. T, 6:00 ; F→Transmissive, N.T,12:00 ; I→Transmissive, W. T, 6:00 K→Transflective, W.T,12:00 L→Transmissive, W.T,12:00 N→Transmissive, Super W.T, 6:00				Q→Transmissive, Super W.T, 12:00 R→Transmissive, Super W.T, O-TFT V→Transmissive, Super W.T, VA TFT X→Transmissive, W.T, VA TFT Y→Transmissive, W.T, IPS TFT Z→Transmissive, W.T, O-TFT						
⑦	A : TFT LCD B : TFT+FR+CONTROL BOARD C : TFT+FR+A/D BOARD D : TFT+FR+A/D BOARD+CONTROL BOARD E : TFT+FR+POWER BOARD					F : TFT+CONTROL BOARD G : TFT+FR H : TFT+D/V BOARD I : TFT+FR+D/V BOARD J : TFT+POWER BD						
⑧	Resolution:											
	A	128160	B	320234	C	320240	D	480234	E	480272	F	640480
	G	800480	H	1024600	I	320480	J	240320	K	800600	L	240400
	M	1024768	N	128128	P	1280800	Q	480800	R	640320	S	480128
	T	800320	U	8001280	V	176220	W	1280398	X	1024250	Y	1920720
	Z	800200	2	1024324	3	7201280						
⑨	D: Digital L : LVDS M:MIPI											
⑩	Interface N:without control board A:8Bit B:16Bit H: HDMI I:I2C Interface : R:RS232 S:SPI Interface U:USB											
⑪	TS : N : Without TS T : resistive touch panel C : capacitive touch panel (G-F-F) G : capacitive touch panel(G-G)											
⑫	Version											
⑬	Special Code	#:Fit in with ROHS directive regulations										

2.Summary

TFT 3.5 is a TN transmissive type color active matrix TFT liquid crystal display that use amorphous silicon TFT as switching devices. This module is a composed of a TFT_LCD module, It is usually designed for industrial application and this module follows RoHs.

WINSTAR DISPLAY Co., Ltd.

3. General Specifications

Item	Dimension	Unit
Size	3.5	inch
Dot Matrix	320 x RGBx 480(TFT)	dots
Module dimension	54.5 (W) x83.0 (H) x 2.1(D)	mm
Active area	48.96 x 73.44	mm
LCD type	TFT, Normally White, Transmissive	
View Direction	6 o'clock	
Gray Scale Inversion Direction	12 o'clock	
Aspect Ratio	Portrait	
Backlight Type	LED, Normally White	
With /Without TP	Without TP	
Surface	Anti-Glare	

*Color tone slight changed by temperature and driving voltage.

4. Absolute Maximum Ratings

Item	Symbol	Min	Typ	Max	Unit
Operating Temperature	TOP	-20	—	+70	°C
Storage Temperature	TST	-30	—	+80	°C

Note: Device is subject to be damaged permanently if stresses beyond those absolute maximum ratings listed above

1. Temp. $\leq 60^{\circ}\text{C}$, 90% RH MAX. Temp. $> 60^{\circ}\text{C}$, Absolute humidity shall be less than 90% RH at 60°C

WINSTAR DISPLAY Co., Ltd.

5. Electrical Characteristics

5.1. Operating conditions:

Item	Symbol	Condition	Min	Typ	Max	Unit
Supply Voltage for digital	IOVCC	—	—	1.8/2.8	3.3	V
Supply Voltage for analog	VCI	—	—	2.8	3.3	V
Power Supply for Current	ICC	IOVCC=VCI =VCC=3.3V	—	13.6	—	mA

5.2. LED driving conditions

Parameter	Symbol	Min	Typ	Max	Unit	Remark
LED current	—	—	160	—	mA	—
LED voltage	VBL+	—	3.2	—	V	Note 1
LED Life Time	—	—	20000	—	Hr	Note 2,3

Note 1 : There are 1 Groups LED

Note 2 : Ta = 25°C

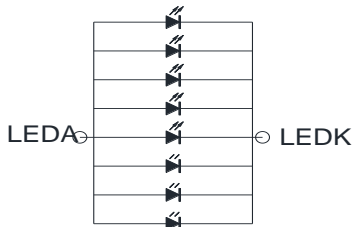

Note 3 : Brightness to be decreased to 50% of the initial value

6.DC CHARATERISTICS

Parameter	Symbol	Rating			Unit	Condition
		Min	Typ	Max		
Low level input voltage	V_{IL}	0	-	0.2VCC	V	
High level input voltage	V_{IH}	0.8VCC	-	VCC	V	

WINSTAR DISPLAY Co., Ltd.

7.AC CHARACTERISTICS

7.1. DBI Type C Option 1 (3-Line Serial Interface)

The 3-line/9-bit serial bus interface of the ILI9488 can be used by setting external pin IM [2:0] as 101. Figure 1 describes an interface with 8080 MCU system interface.

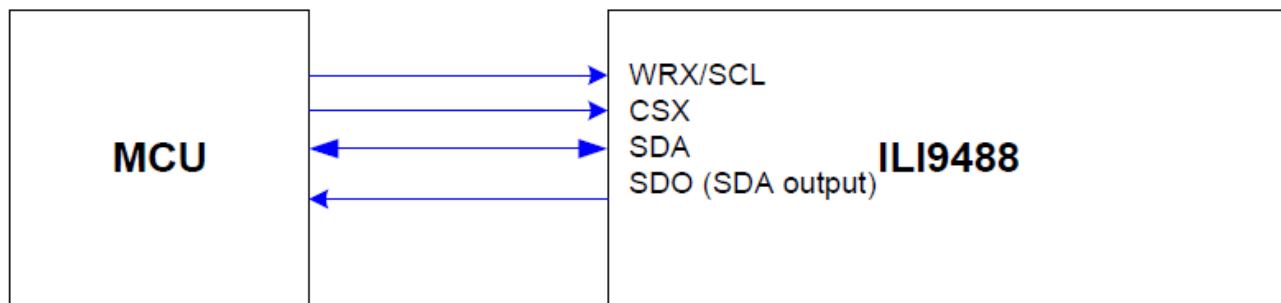

Figure 1: 3-Line Serial Interface

The available display data formats are:

*8 colors, RGB 1, 1, 1 bits input (set Standard Command 3Ah, DBI [2:0] as 001)

*262K-Colors, RGB 6, 6, 6 bits input data (set Standard Command 3Ah, DBI [2:0] as 110)

7.1.1 SPI Data for 3-bit/pixel (RGB 1-1-1 Bits Input), 8-color

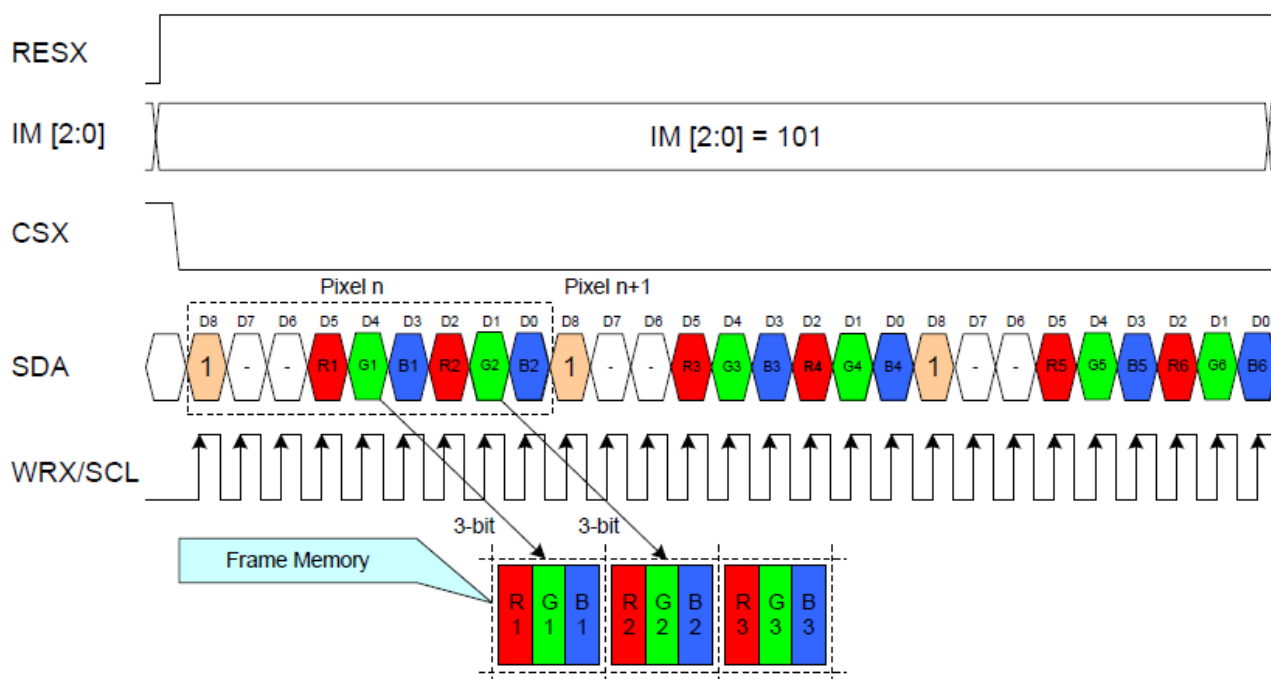

Figure 2: SPI Data for 3 bit/pixel (RGB 1-1-1 Bits Input), 8-color

Notes:

1. One pixel data contains 3-bit color depth information.

7.1.2. SPI Data for 18-bit/pixel (RGB 6-6-6 Bits Input), 262K-color

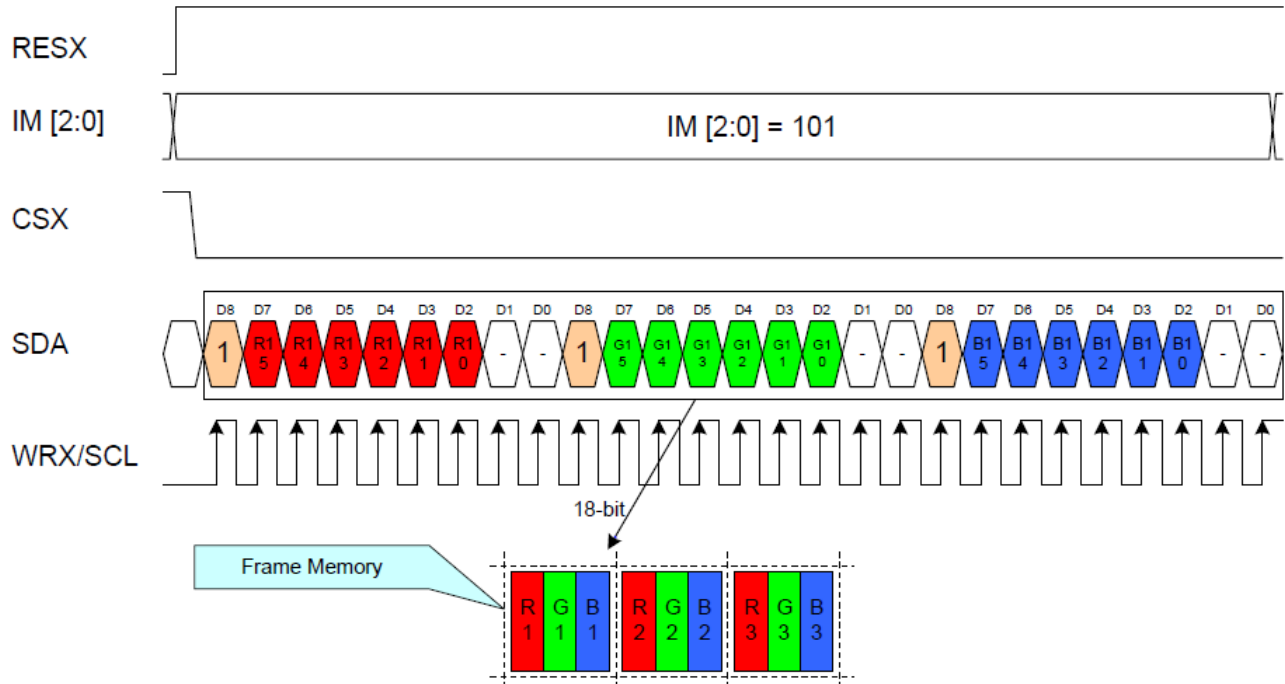

Figure 3: SPI Data for 18-bit/pixel (RGB 6-6-6 Bits Input), 262K-color

Notes:

1. One pixel data contains 18-bit color depth information.
2. The most significant bits are: R x 5, G x 5, and B x 5.
3. The least significant bits are: R x 0, G x 0, and B x 0.

Read data through 3-line SPI mode

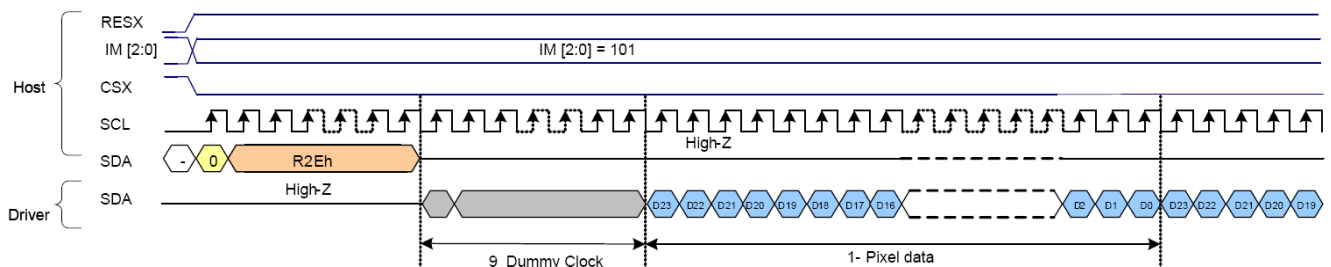

Figure 4: 3-Line SPI Mode Read Data

Note: „-“ = void

7.2. 8-bit Parallel MCU Interface

The DBI TYPE B 8-bit parallel bus interface of the ILI9488 is used by setting the external pin IM [2:0] as 011. Figure 5 shows this system interface.

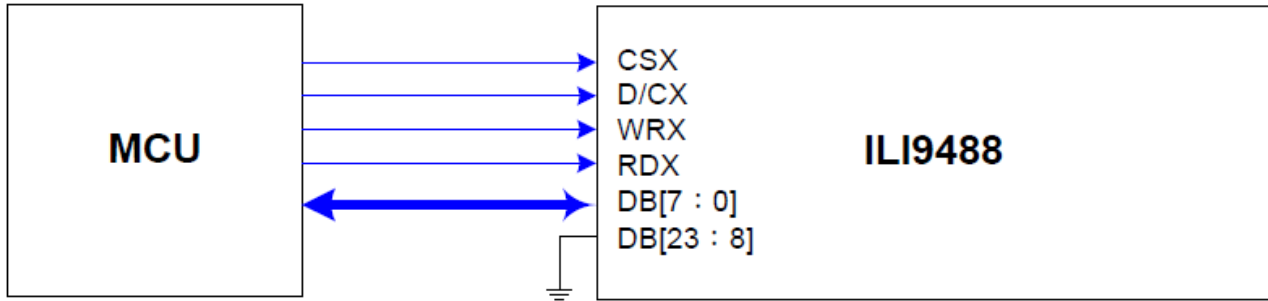

Figure 5: 8-bit Parallel MCU Interface

The available display data formats are:

*65K-Colors, RGB 5, 6, 5 bits input data (set Standard Command 3Ah, DBI [2:0] as 101)

*262K-Colors, RGB 6, 6, 6 bits input data (set Standard Command 3Ah, DBI [2:0] as 110)

7.2.1. 8-bit Data Bus for 16-bit/pixel (RGB 5-6-5 Bits Input), 65K-color

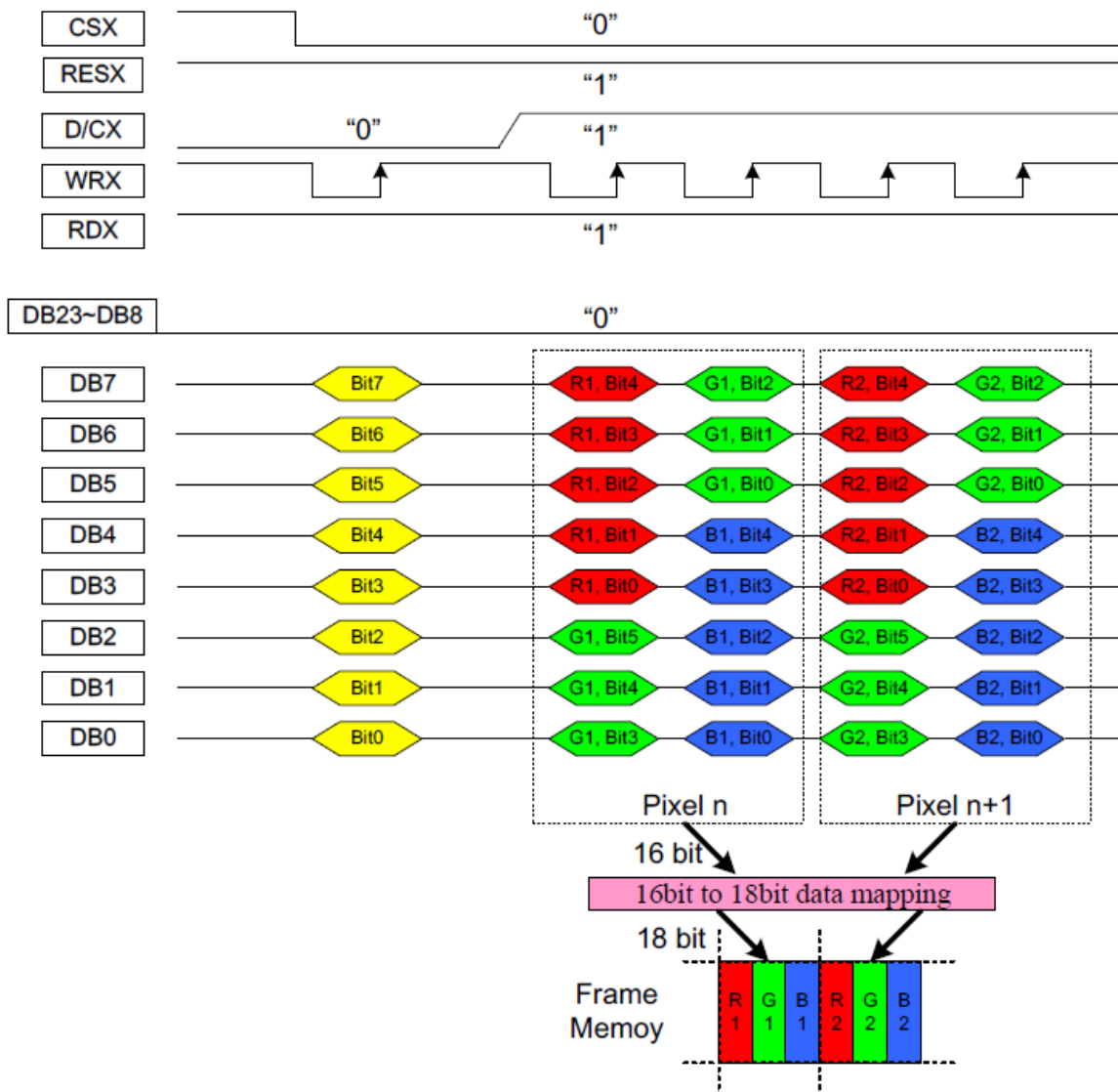

Figure 6: 8-bit Data Bus for 16-bit/pixel (RGB 6-5-6 Bits Input), 65K-color

Notes:

1. The data order is as follows: MSB = DB7, LSB = DB0, and picture data is MSB = Bit 5, LSB = Bit 0 for Green data, and MSB = Bit 4, LSB = Bit 0 for Red and Blue data.
2. 2-times transfer is used to transmit 1 pixel data to the 16-bit color depth information.

7.2.2. 8-bit Data Bus for 18-bit/pixel (RGB 6-6-6 Bits Input), 262K-color

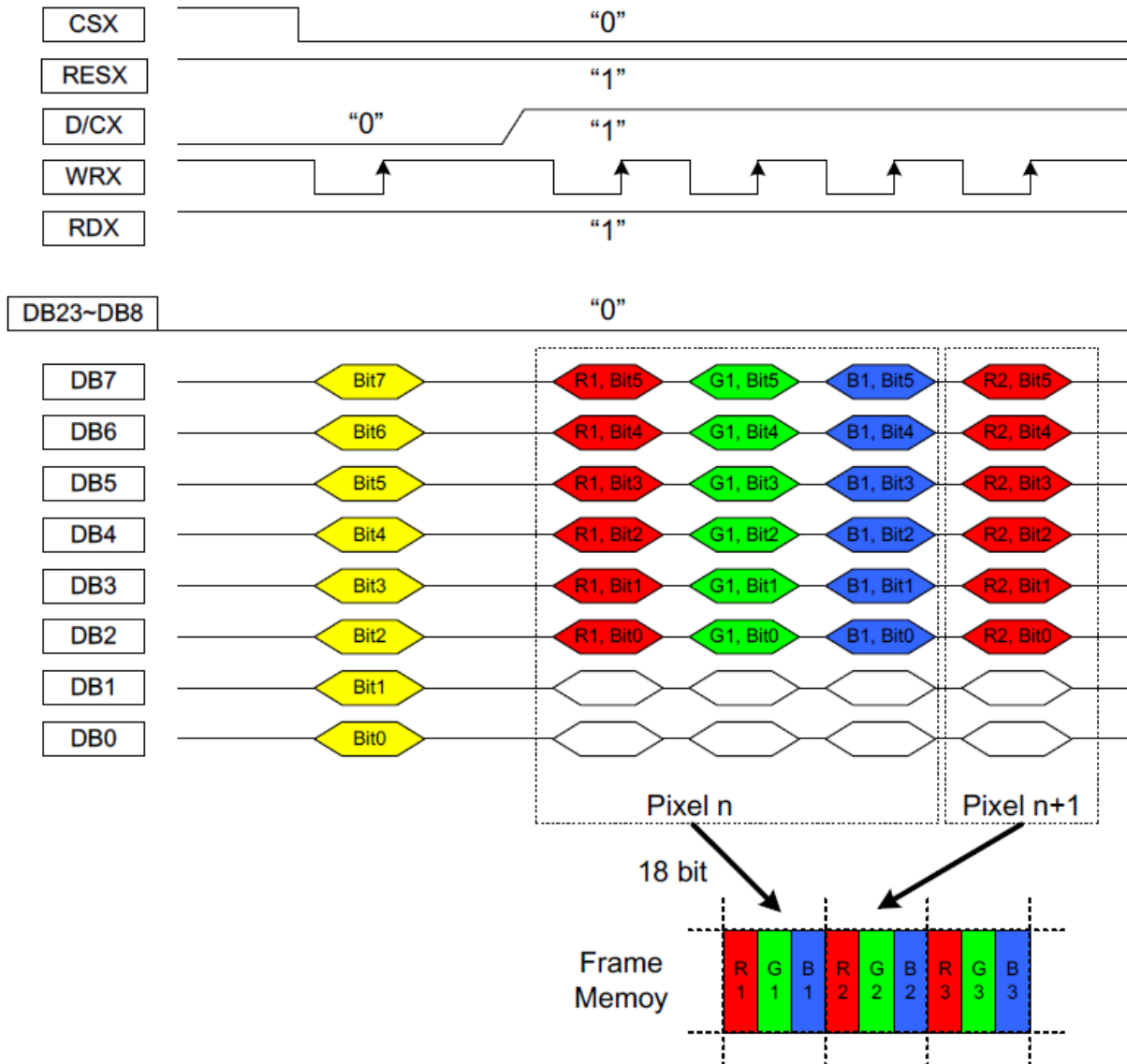

Figure 7: 8-bit Data Bus for 18-bit/pixel (RGB 6-6-6 Bits Input), 262K-color

Notes:

1. The data order is as follows: MSB = DB7, LSB = DB0, and picture data is MSB = Bit 5, LSB = Bit 0 for Green, Red and Blue data.
2. 3-times transfer is used to transmit 1 pixel data to the 18-bit color depth information.

7.3. 16-bit Parallel MCU Interface

The 8080-system 16-bit parallel bus interface of the ILI9488 can be used by setting external pin IM [2:0] as 010.

Figure 8 shows this system interface.

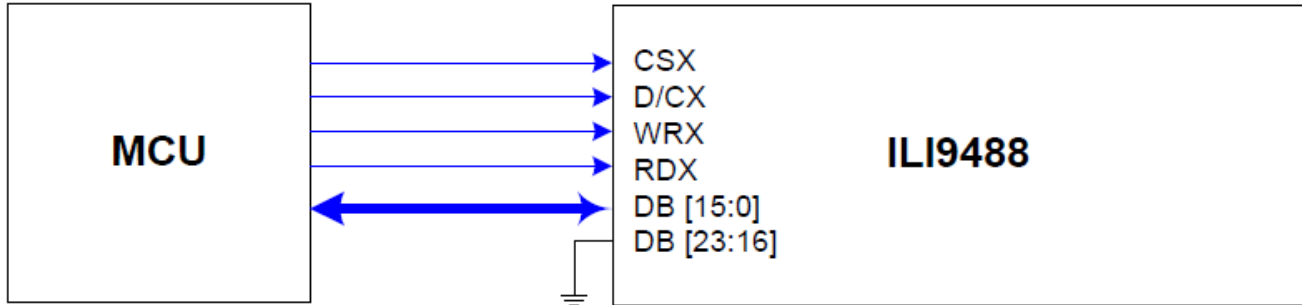

Figure 8: 16-bit Parallel MCU Interface

The available display data formats are:

65K-Colors, RGB 5, 6, 5 bits input data (set Standard Command 3Ah, DBI [2:0] as 101)

262K-Colors, RGB 6, 6, 6 bits input data (set Standard Command 3Ah, DBI [2:0] as 110)

WINSTAR DISPLAY COPY

7.3.1 16-bit Data Bus for 16-bit/pixel (RGB 5-6-5 Bits Input), 65K-color

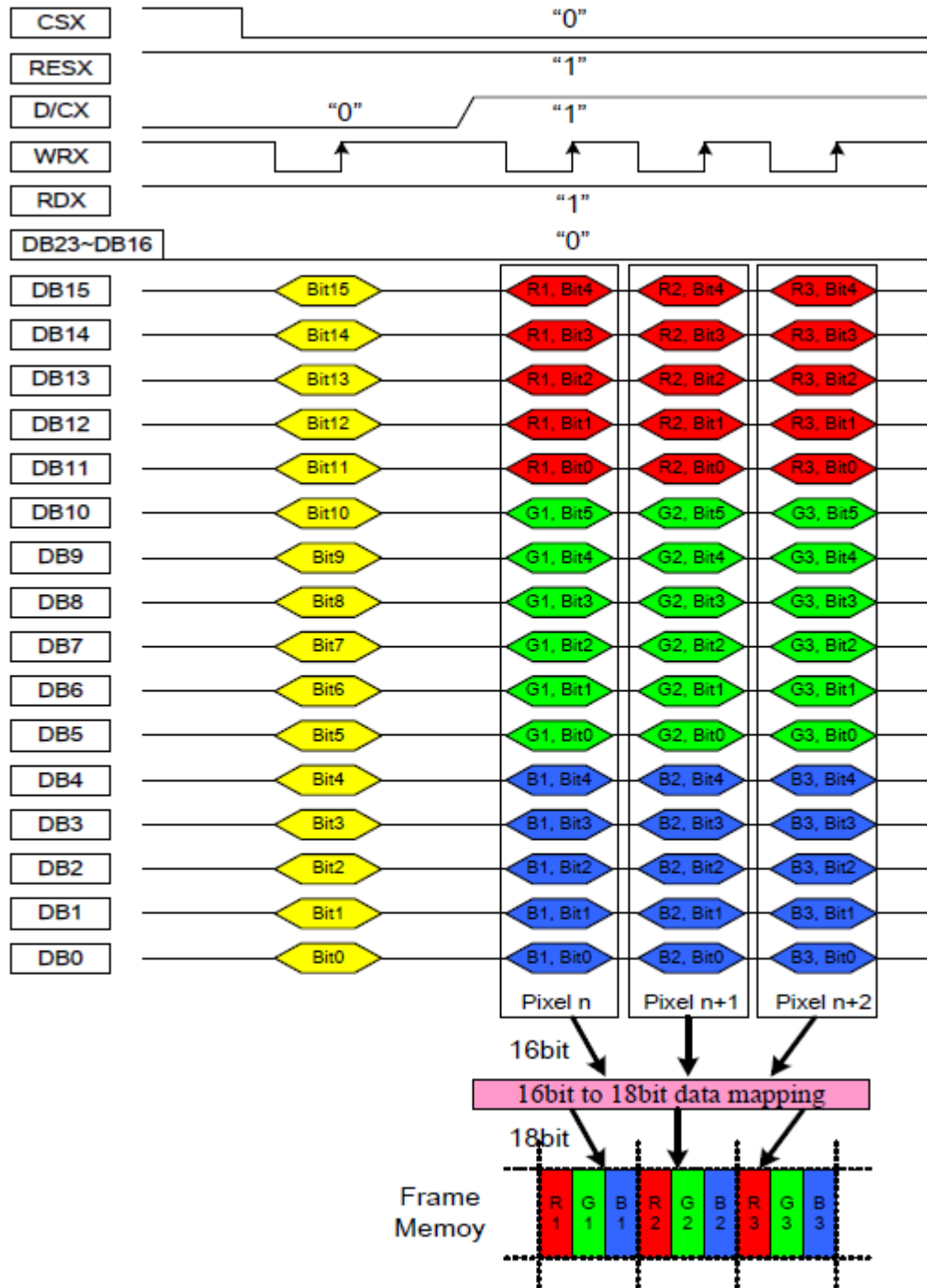

Figure 9: 16-bit Data Bus for 16-bit/pixel (RGB 5-6-5 Bits Input), 65K-color

Notes:

1. The data order is as follows: MSB = DB15, LSB = DB0, and picture data is MSB = Bit 5, LSB = Bit 0 for Green data, and MSB = Bit 4, LSB = Bit0 for Red and Blue data.
2. 1-time transfer is used to transmit 1 pixel data to the 16-bit color depth information.

7.3.2 16-bit Data Bus for 18-bit/pixel (RGB 6-6-6 Bits Input), 262K-color

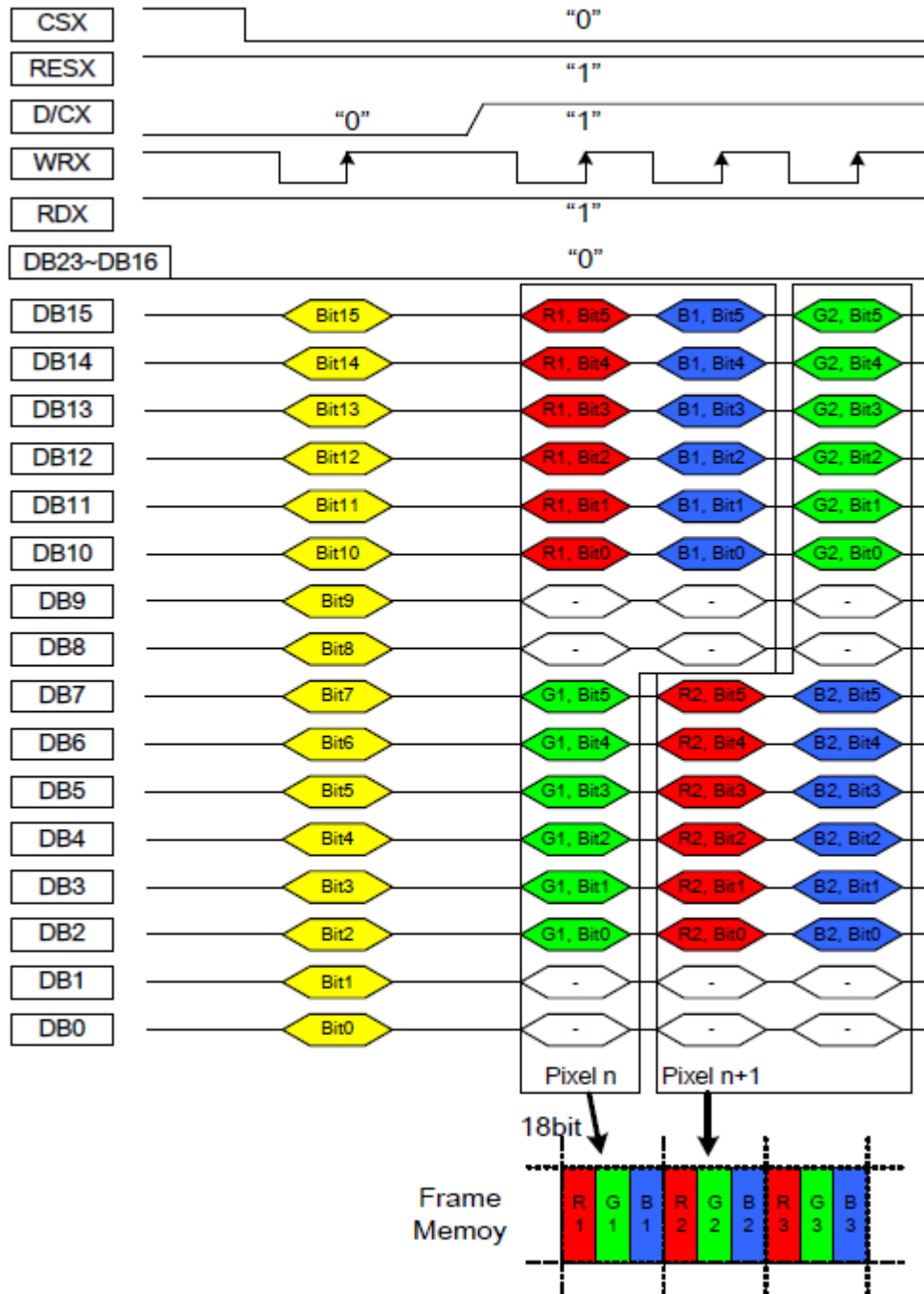

Figure 10: 16-bit Data Bus for 18-bit/pixel (RGB 6-6-6 Bits Input), 262K-color

Notes:

1. The data order is as follows: MSB = DB15, LSB = DB0, and picture data is MSB = Bit 5, LSB = Bit 0 for Green, Red and Blue data.
2. 3-times transfer is used to transmit 2 pixel data to the 18-bit color depth information.

7.4. Other display data format, Please reference the ILI9488 Spec

8. Optical Characteristics

Item	Symbol	Condition.	Min	Typ.	Max.	Unit	Remark	
Response time	Tr	$\theta = 0^\circ \cdot \Phi$	-	4	8	.ms	Note 3,5	
	Tf	$= 0^\circ$	-	12	24	.ms		
Contrast ratio	CR	At optimized viewing angle	400	500	-	-	Note 4,5	
Color Chromaticity	White	Wx	$\theta = 0^\circ \cdot \Phi$	0.253	0.303	0.353	Note 2,6,7	
		Wy	$= 0$	0.265	0.325	0.385		
Viewing angle (Gray Scale Inversion Direction)	Hor.	Θ_R	$CR \geq 10$	-	45	-	Deg.	Note 1
		Θ_L		-	45	-		
	Ver.	Φ_T		-	45	-		
		Φ_B		-	20	-		
Brightness	-	-	280	320	-	cd/m2	Center of display	

Ta=25±2°C

Note 1: Definition of viewing angle range

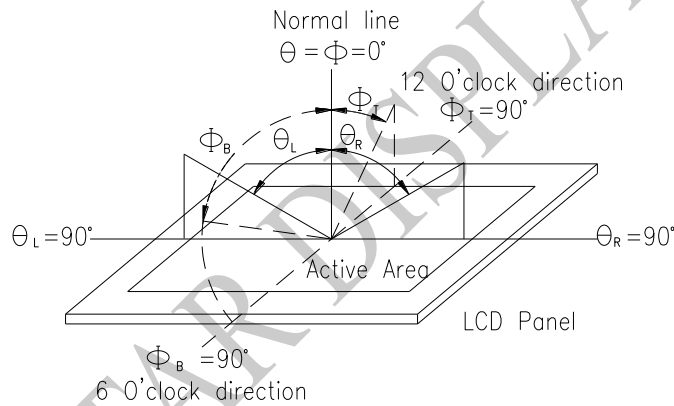

Fig. 8.1. Definition of viewing angle

Note 2: Test equipment setup:

After stabilizing and leaving the panel alone at a driven temperature for 10 minutes, the measurement should be executed. Measurement should be executed in a stable, windless, and dark room. Optical specifications are measured by Topcon BM-7 luminance meter 1.0° field of view at a distance of 50cm and normal direction.

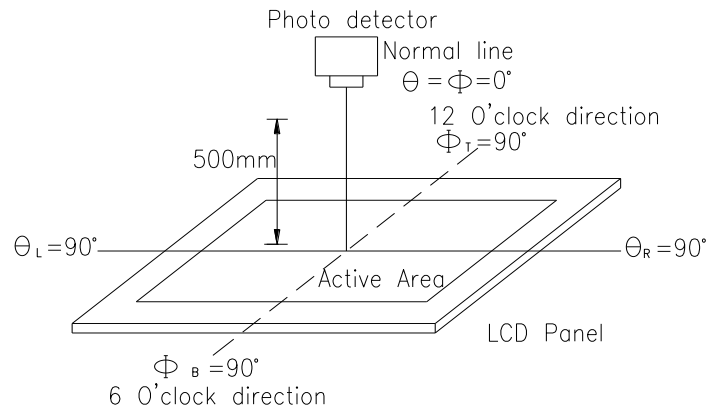
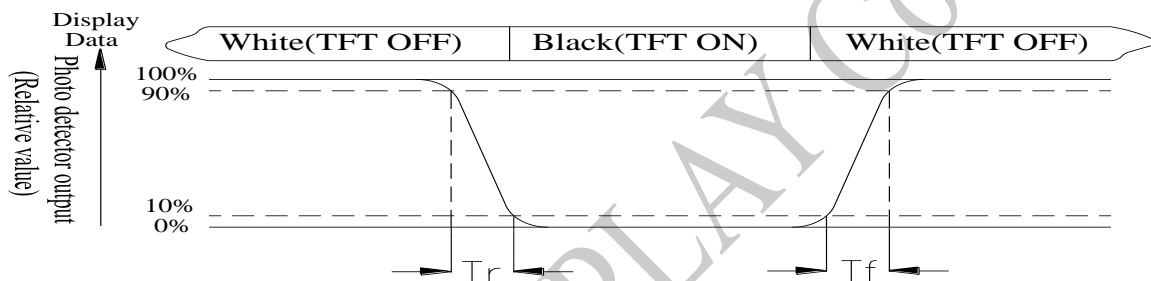

Fig. 8.2. Optical measurement system setup

Note 3: Definition of Response time:

The response time is defined as the LCD optical switching time interval between “White” state and “Black” state. Rise time, T_r , is the time between photo detector output intensity changed from 90% to 10%. And fall time, T_f , is the time between photo detector output intensity changed from 10% to 90%



Note 4: Definition of contrast ratio:

The contrast ratio is defined as the following expression.

$$\text{Contrast ratio (CR)} = \frac{\text{Luminance measured when LCD on the "White" state}}{\text{Luminance measured when LCD on the "Black" state}}$$

Note 5: White $V_i = V_{i50} \pm 1.5V$

Black $V_i = V_{i50} \pm 2.0V$

“±” means that the analog input signal swings in phase with VCOM signal.

“±” means that the analog input signal swings out of phase with VCOM signal.

The 100% transmission is defined as the transmission of LCD panel when all the input terminals of module are electrically opened.

Note 6: Definition of color chromaticity (CIE 1931)

Color coordinates measured at the center point of LCD

Note 7: Measured at the center area of the panel when all the input terminals of LCD panel are electrically opened.

9.Interface

LCM PIN Definition

NO	Symbol	Function	I/O
1	LEDK	Cathode of LED backlight	P
2	LEDA	Anode of LED backlight.	P
3	IM0	Note 1	I
4	IM1	Note 1	I
5	IM2	Note 1	I
6	NRESET	System reset pin.	I
7	VSYNC	Frame synchronizing signal	I
8	HSYNC	Line synchronizing signal	I
9	DOTCLK	Dot clock signal	I
10	DE	A data ENABLE input signal	I
11-28	DB17-0	Data bus	I/O
29	SDA	serial data input/output bi-direction pin	I/O
30	NRD	Read strobe signal. Read out data when RDX is Low.	I
31	NWR_SCL	Write data when WRX is Low.	I
32	DNC	register select	I
33	NCS	Chip select signal	I
34	IOVCC	Power supply(TYP:1.8V/2.8V).	P
35	VCI	Power supply(TYP:2.8V).	P
36	GND	Ground	P
37	NC	Connection	
38	NC	Connection	
39	NC	Connection	
40	NC	Connection	

Note 1:

IM2	IM1	IM0	Interface	Data Pin in Use
0	0	0	24-bit bus (DB_EN=1)	DB [23:0]
0	0	0	18-bit bus (DB_EN=0)	DB [17:0]
0	0	1	9-bit bus	DB [9:0]
0	1	0	16-bit bus	DB [15:0]
0	1	1	8-bit bus	DB [7:0]
1	0	1	Option1 (3-line SPI)	SDA,SDO

WINSTAR DISPLAY Co., Ltd.

10. Block Diagram

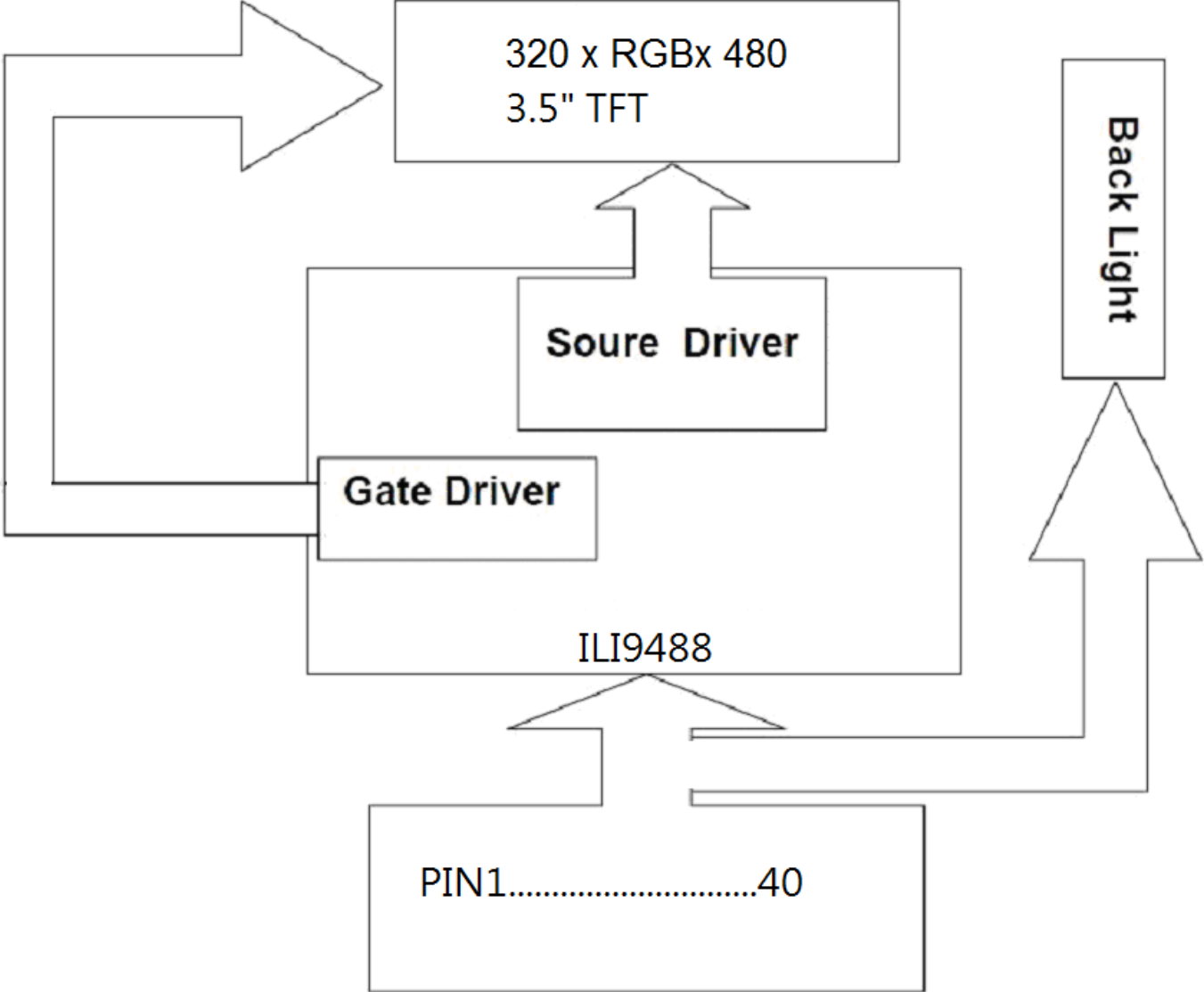

11. Reliability

Content of Reliability Test (Wide temperature, -20°C ~70°C)

Environmental Test			
Test Item	Content of Test	Test Condition	Note
High Temperature storage	Endurance test applying the high storage temperature for a long time.	80°C 96hrs	2
Low Temperature storage	Endurance test applying the low storage temperature for a long time.	-30°C 96hrs	1,2
High Temperature Operation	Endurance test applying the electric stress (Voltage & Current) and the thermal stress to the element for a long time.	70°C 96hrs	—
Low Temperature Operation	Endurance test applying the electric stress under low temperature for a long time.	-20°C 96hrs	1
High Temperature/ Humidity Operation	The module should be allowed to stand at 40 °C, 90%RH max	40°C, 90%RH 96hrs	1,2
Thermal shock resistance	The sample should be allowed stand the following 10 cycles of operation <div style="text-align: center;"> <p style="margin: 0;">-20°C 25°C 70°C</p> <p style="margin: 0;">30min 5min 30min</p> <p style="margin: 0;">1 cycle</p> </div>	-20°C/70°C 10 cycles	—
Vibration test	Endurance test applying the vibration during transportation and using.	Total fixed amplitude : 1.5mm Vibration Frequency : 10~55Hz One cycle 60 seconds to 3 directions of X, Y, Z for Each 15 minutes	3
Static electricity test	Endurance test applying the electric stress to the terminal.	VS=±600V(contact), ±800v(air), RS=330Ω CS=150pF 10 times	—

Note1: No dew condensation to be observed.

Note2: The function test shall be conducted after 4 hours storage at the normal Temperature and humidity after remove from the test chamber.

Note3: The packing have to including into the vibration testing.

12. Contour Drawing

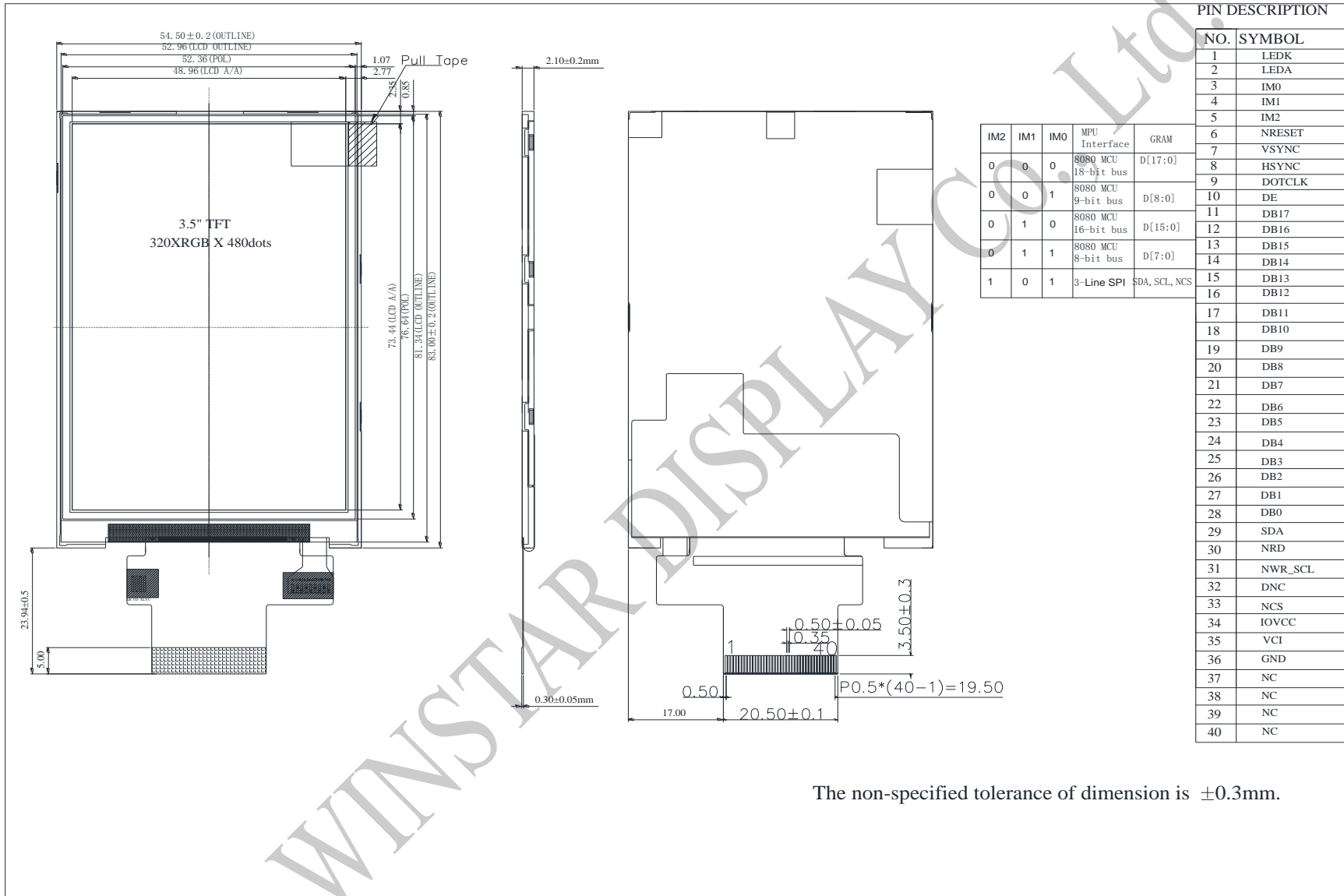



1、Panel Specification :

- 1. Panel Type : Pass NG , _____
- 2. View Direction : Pass NG , _____
- 3. Numbers of Dots : Pass NG , _____
- 4. View Area : Pass NG , _____
- 5. Active Area : Pass NG , _____
- 6. Operating : Pass NG , _____
- 7. Storage Temperature : Pass NG , _____
- 8. Others : _____

2、Mechanical

- 1. PCB Size : Pass NG , _____
- 2. Frame Size : Pass NG , _____
- 3. Material of Frame : Pass NG , _____
- 4. Connector Position : Pass NG , _____
- 5. Fix Hole Position : Pass NG , _____
- 6. Backlight Position : Pass NG , _____
- 7. Thickness of PCB : Pass NG , _____
- 8. Height of Frame to PCB : Pass NG , _____
- 9. Height of Module : Pass NG , _____
- 10. Others : Pass NG , _____

3、Relative Hole Size :

- 1. Pitch of Connector : Pass NG , _____
- 2. Hole size of Connector : Pass NG , _____
- 3. Mounting Hole size : Pass NG , _____
- 4. Mounting Hole Type : Pass NG , _____
- 5. Others : Pass NG , _____

4、Backlight Specification :

- 1. B/L Type : Pass NG , _____
- 2. B/L Color : Pass NG , _____
- 3. B/L Driving Voltage (Reference for LED) : Pass NG , _____
- 4. B/L Driving Current : Pass NG , _____
- 5. Brightness of B/L : Pass NG , _____
- 6. B/L Solder Method : Pass NG , _____
- 7. Others : Pass NG , _____



Winstar Module Number : _____

Page: 2

5、Electronic Characteristics of Module :

- 1. Input Voltage : Pass NG , _____
- 2. Supply Current : Pass NG , _____
- 3. Driving Voltage for LCD : Pass NG , _____
- 4. Contrast for LCD : Pass NG , _____
- 5. B/L Driving Method : Pass NG , _____
- 6. Negative Voltage Output : Pass NG , _____
- 7. Interface Function : Pass NG , _____
- 8. LCD Uniformity : Pass NG , _____
- 9. ESD test : Pass NG , _____
- 10. Others : Pass NG , _____

6、Summary :

Sales signature : _____

Customer Signature : _____

Date : / / _____

